



ALUMINIUM
Greenhouse

Riga XL Factory Manual

Version 2.2022

Assembly Instructions

Riga XL 5, 6, 7, 8, 9



Assembly Animation Video
is available on our YouTube page,
find the link at www.exaco.com or
scan the QR code above.



www.exaco.com
877-760-8500
customerservice@exaco.com

Dear Gardening Friend,

Thank you for buying a Riga XL greenhouse from Exaco! Please read these Assembly Instructions and helpful suggestions carefully. Our animated YouTube assembly video will be extremely helpful during assembly - find a link to our YouTube page on our website at www.exaco.com. If you have questions or run into any difficulty, please give us a call! Good Luck!

What to do First:

Check all the boxes you have received for damage and make sure you have the correct quantity. The driver will have a delivery receipt called a Bill of lading, this will have the quantity of boxes you should be receiving.

If you are missing a box or if any of the boxes are damaged - write this on the Bill of Lading before the driver leaves. Notify Exaco as soon as possible if any of the boxes are damaged or missing.

Note:

Please do not refuse any of the boxes or the whole shipment, because of any damage. We will gladly replace any damaged items. Sending replacement parts is a simple and easy process.

In the case of damage:

Contact Exaco Customer Service at 877-760-8500 or email us at customerservice@exaco.com. Photos will help us see if there are packaging deficiencies and change them in the future. This will also help identify parts.

Storage:

Please keep all the boxes in a dry place and protected against sunlight (see note regarding polycarbonate). If stored outdoors, protect securely with tarps.

Placing your greenhouse:

Place your greenhouse in a location with as much sun as possible. We do not recommend putting it directly under trees since branches might damage the glazing. If you intend to primarily grow vegetables: north-south orientation is recommended if possible; for flowers: east-west.

Protection from heavy winds:

If your area is subject to very strong wind gusts we strongly recommend against putting your greenhouse up without some kind of protection: a row of small trees, large shrubs or a wooden fence. Please contact Exaco Trading customer service to discuss additional anchoring options and window bracing kits for high wind.

Warning:

Do not attempt assembly of this greenhouse in windy conditions. Your glazing panels might blow away and become damaged. Damages during assembly process, due to bad weather, are not covered by our warranty.

Table of Contents

Before You Begin/ Important information.....	1-4
Contents of Boxes	
Overview of boxes.....	5
Polycarbonate panel sizes/count.....	6
Basic Construction Components (aluminum extrusions)	7
Accessories Bag/ Hardware and Bracket components.....	8
Window and Door Components.....	9-10
Connecting Long Profiles/Extrusions.....	11
Extra bracing @ center curves for XL 7/8/9 only.....	12-13
Planning Foundation/Anchoring your greenhouse	
Foundation Frame (optional accessory)	14
Anchoring the greenhouse without a foundation frame.....	15
Foundation Plan and Measurements.....	16
Placing on a stem wall using the Door Extension Kit.....	16
Gable Assembly (front and back are identical)	17-18
Side Wall Assembly.....	19
Attaching Rear Gable	20
Roof Windows	
Roof Window Parts.....(See page 9)	
Roof Window Assembly.....	21
Roof Window Auto Opener.....	22-23
Wind Restraints for High Wind (optional).....	24
Door Assembly (Same for front/back doors)	
Door Bottom Half	25
Door Top Half.....	26
Door Handle installation.....	27
Sealing the Greenhouse.....	28
Auto Opener Piston Maintenance and Troubleshooting.....	29-30
Optional Accessories (may not be included with your kit)	
Riga XL Shelf Assembly.....	31-34
Exhaust Fan Installation.....	35
Intake Vent Installation.....	36
Riga Metal Hook Assembly.....	37
Riga Plastic Hook Assembly.....	37
Assembly Help Contact Information.....	front and back covers

Important note regarding polycarbonate glazing during assembly:

The ISO-cellular sheets (polycarbonate glazing) must be placed with the UV-coated side to the outside. On the protective film, there will be a corresponding note indicating "UV" or "2UV", most panels should be coated on both sides, but if you are unsure, please give us a call.

Loosen the protection film only at the edge and the complete rest of the foil only after the panel is securely in place. HOWEVER, do not leave the film on more than 1 day in the sun as the film can burn tight to the polycarbonate and will be extremely difficult to remove.

Do not strip it completely off when unpacking the goods because then you cannot see the side with the UV-protection. The film will also protect the polycarbonate from scratches during assembly.

Unlike most greenhouses, the mounting of the aluminium profiles is done together with the glazing. This results in an absolutely secure glazing and the best possible stability of the greenhouse.

Assembly:

Some of the assembly can be by one person, but it is most helpful to have a second pair of hands available. Assembling the windows, doors and gables ahead of time will make you familiar with the process and will make the main assembly go quicker and more smoothly.

Once the roof beam is attached to your gable, it is necessary to have an additional person to hold/steady the roof beam or use stable support such as: stay bars, ladders, straps or other equipment. A third person is extremely helpful when installing the curved side walls.

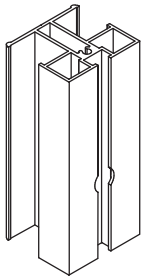

Special Note: Much of the greenhouse is assembled with series of bolts that are inserted into the channels on the aluminum profiles/extrusions. If you miss inserted a bolt where needed, there are insertion points in many of the vertical and curved profiles/extrusions. You may also create your own insertion point with a 1/2" drill bit. This will not compromise the integrity of the structure.

What you will need:

- Patience - do not rush - Make it a fun build
- 2 people (3 will make it easier - especially when inserting the glazing panels)
- Gloves - the ends of the aluminium profiles can be sharp

- Measuring tape - a combination metric/inch tape measure is preferred
- 2 A-frame step ladders (10' and 8' preferable)
- 2 Rubber mallets
- Adjustable wrench
- 10 mm socket wrench
- 10 mm wrench

- Philips head screwdriver (Drill or impact drill can be used with caution) - Level

- Lithium Grease - helpful to slide profiles along floor/roof profiles and windows along roof beam
- Permanent Marker (to mark glazing panels)
- Tape can be helpful to hold bolts in desired location during assembly

Recommended Support Structure for Riga XL Assembly

When assembling a greenhouse of this length, we recommend using supports to hold up the ridge profile while you work. You can use a 2x4 piece of wood that is 9' 8" tall. Here are some examples below.







Packaging Counts and Contents:

Depending on the size greenhouse you have, your box count will vary.

Quantity			Content table
1x	Basic constructions	Gables	Page 7
1x	Basic constructions	Long parts (with floor profile - gable)	Page 7
1x	Roof window/door	You may have additional smaller boxes of roof windows depending on model size	Page 9-10
1x	Hardware & Accessories	Seals, automatic window opener, etc.	Page 8
2x bundles	Curved center profiles	May vary by size of model	Page 7
4x	Glazing	May vary by size of model	Page 6
2x	Foundation frame	(special accessories)	Page 14-15

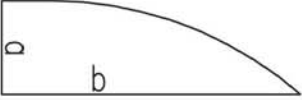

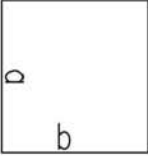
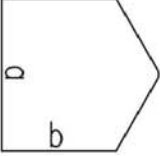
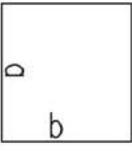
You may have additional boxes for optional accessories as well such as shelving, ventilation, heating and other items.

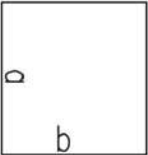
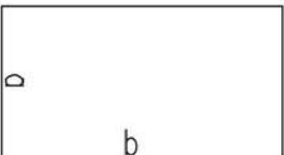
Polycarbonate Glazing Panels: 16mm triple wall





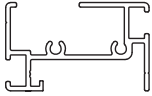

Riga XL Size	Curved Panel for Gables	Curved Panel small (gables)	Square Panel (gables)	5 Sided Panel (gables)	Door Panels	Side Wall Panels Large	Roof Windows	Side wall panels under roof windows
millimeters	602 x 1922	980 x 727	980 x 944	980 x 1008	888 x 835	980 x 3893	888 x 943	980 x 2830
								
Riga XL 5	Quantity and Size (a,b) 4	Quantity and Size (a,b) 4	Quantity and Size (a,b) 8	Quantity and Size (a,b) 2	Quantity and Size (a,b) 4	Quantity and Size (a,b) 8	Quantity and Size (a,b) 4	Quantity and Size (a,b) 4
Riga XL 6	Quantity and Size (a,b) 4	Quantity and Size (a,b) 4	Quantity and Size (a,b) 8	Quantity and Size (a,b) 2	Quantity and Size (a,b) 4	Quantity and Size (a,b) 6	Quantity and Size (a,b) 4	Quantity and Size (a,b) 4
Riga XL 7	Quantity and Size (a,b) 4	Quantity and Size (a,b) 4	Quantity and Size (a,b) 8	Quantity and Size (a,b) 2	Quantity and Size (a,b) 4	Quantity and Size (a,b) 8	Quantity and Size (a,b) 6	Quantity and Size (a,b) 6
Riga XL 8	Quantity and Size (a,b) 4	Quantity and Size (a,b) 4	Quantity and Size (a,b) 8	Quantity and Size (a,b) 2	Quantity and Size (a,b) 4	Quantity and Size (a,b) 10	Quantity and Size (a,b) 6	Quantity and Size (a,b) 6
Riga XL 9	Quantity and Size (a,b) 4	Quantity and Size (a,b) 4	Quantity and Size (a,b) 8	Quantity and Size (a,b) 2	Quantity and Size (a,b) 4	Quantity and Size (a,b) 10	Quantity and Size (a,b) 8	Quantity and Size (a,b) 8

Contents of main box - basic construction components.

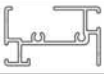









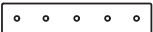



Profiles for both gables:

Profile design	Pos.	Description	Quantity	Length [mm]
	1	Front/Back floor profiles	2	4145
	2	Edge stay bar - curved - right side	2	
	3	Edge stay bar - curved - left side	2	
	4	Vertical profile - middle - left - with 50° angle at top	2	1929
	5	Vertical profile - middle - right - with 50° angle at top	2	1929
	6	Vertical door profile - left - with 30° angle at top	2	2641
	7	Vertical door profile - right - with 30° angle at top	2	2641
	8	Crossbar	10	952

Profiles for side walls:

Profile Design	Pos. Type	Description	Quantity/Length [mm]				
			XL 5	XL 6	XL 7	XL 8	XL 9
	18	Floor Profile - Side	2 4909	2 5903	2 6898	2 7893	2 8888
	19	Curved Center Profiles	8	10	12	14	16
	22	Lateral Supports (Wind Braces)	4 4965	4 5960	4 6955	4 7949	4 8944
	25	Cross Bar (Under Window)	4 952	4 952	4 952	4 952	4 952
	28	Roof Beam	1 5008	1 6002	1 6996	1 7990	1 8984
	31	Re-Enforcement Bar (Roof Beam)	1 4966	1 5960	1 6951	1 7944	1 8940

Hardware bag basic construction

Part design	Pos.	Description	Quantity
	100	Plastic corner connector	4
	101	Straight connector plate for cross bars above doors	4
	102	T-connector slanted for door upright and edge clamp	4
	103	T-connector door profiles to cross bars	8
	104	T-connector slanted vertical profile middle/cross bar/ edge clamp	4
	105	Floor profile connectors inside lower corner	4
	107	Hexagon head bolts M6 x 16mm + nuts M6 Bolts for assembly	160*
	108	Washers to be used with the lateral supports	28
	110	Insulation seal 6 - 8mm thick used on the inside where polycarbonate meets floor profile	See table below.
	111	Phillips head screws 4.2 x 13mm for cross bar/roof beam- end cap/ cover plate	12
	142	Phillips head screws 4.2 x 50mm for cross bars in front and back walls	4
	113	Phillips head screws 4.8 x 16mm for floor profile corner connectors	16
	114	Roof beam - end cap/cover plate	2
	115	Connector plate for cross bars under windows	4/8/8 depends on model
	116	Floor profile corner con- nector covers	4
	117	Self drilling screws 3,5 x 13 t-connector 102 + 104	32

*plus substitute screws

Heavy insulation seal 6- 8 mm in pre cut section

Type \ Length	952 mm	571 mm
Riga XL 4	12 pc	4 pc
Riga XL 5	14 pc	4 pc
Riga XL 6	16 pc	4 pc

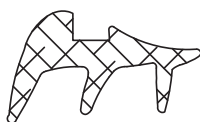



Used on the inside after greenhouse is assembled. It will insert where the polycarbonate sheets meet the floor profile.

Type \ Length	952 mm	571 mm
Riga XL 7	18 pc	4 pc
Riga XL 8	20 pc	4 pc
Riga XL 9	22 pc	4 pc

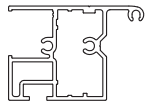

Profiles for each roof window: XL 5-7 have 4 roof windows / XL 8 has 6 / XL 9 has 8

Profile design	Pos.	Description	Quantity	Length [mm]
	34	Window profile - roof	2	865
	35	Window profile - roof	2	993

Profiles for each divided revolving door - at the bottom - XL greenhouse have 2

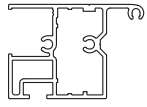

Profile design	Pos.	Description	Quantity	Length [mm]
	44	Door profile - left with borings for Sash lock	1	887
	45	Door profile - right with hinge borings	1	887
	46	Door profile - top	1	864
	48	Door profile - bottom	1	864
	47	Rectangular tube with cross holes	1	933

Profiles for each divided revolving door - top - XL greenhouse have 2

Profile design	Pos.	Description	Quantity	Length [mm]
	41	Door profile - left	1	949
	42	Door profile - right with hinge borings	1	949
	48	Door profile - top	1	864
	43	Door profile - bottom with large hole for door handle	1	864



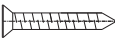







Accessories and hardware for each roof window

XL5 and XL6 have 4 roof windows; XL7 and XL8 have 6 roof windows; XL 9 has 8 roof windows











Part design	Pos.	Description	Quantity	Length [mm]
 *	126	T-seal Note: The rubber seal is in one bundle for all doors and windows. Cut accordingly please.	1 2	974 1027
	127	Plastic corner connector	2x left 2x right	
	112	Phillips head screws 4,2 x 60	8	
	107	Hexagon head screws M6 x 16 + nut M6	3	
	143	Glazing block 30 x 16 x 4	2	

* **Note:** The rubber seal is in one bundle for all doors and windows. Cut accordingly please.

Accessories bag for divided revolving door - at the bottom - (2 bags)

Part Design	Pos.	Description	Quantity	Length [mm]
	135	Hinge	2	
	136	Sash lock	1	
	137	End cap for rectangular tube	2	
	138	T-seal Note: The rubber seal is in one bundle for all doors and windows. Cut accordingly please.	2 2	936 973
	139	Phillips head screw 4,8 x 25 (for hinges)	4	
	140	Phillips head screw 4,8 x 16 (for hinges)	4	
	112	Phillips head screw 4,2 x 60 (for doors)	8	
	141	Phillips head screw 3,5 x 22 (sash lock)	2	
	142	Phillips head screw 4,2 x 50 (to attach square tube)	2	
	143	Glazing block 30 x 16 x 4	2	
	127	Plastic corner connector	2x left 2x right	

Accessories bag for divided revolving door - top - (2 bags)

Part design	Pos.	Description	Quantity	Length inches
see page 19/20	150	Door sets, 8-piece (Assembly see page 18.)	1	
	112	Phillips head screws 4.2 x 60mm (door)	8	
	143	Glazing block 30 x 16 x 4	2	
	153	T-seal Note: The rubber seal is in one bundle for all doors and windows. Cut accordingly please.	2 2	966 973
	135	Hinge	2	
	139	Phillips head screws 4.8 x 25mm (hinges)	4	
	140	Phillips head screws 4.8 x 16mm (hinges)	4	
	136	Sash Lock	1	
	141	Phillips head screws 3.5 x 22mm (Sash Lock)	2	
	158	Door holder - metal - 2 parts	1	
	159	Phillips head screws 3.5 x 16mm (door holder)	4	
	127	Plastic corner connectors	1x left 1x right	

Note: The rubber seal is bundled in one bundle for all doors and windows. Cut accordingly please.

Connecting Long Profiles

Your long aluminum extrusions may come in sections that need to be connected before assembly. Please see examples below. The Grub Screws are already in the channels, you will need to loosen them and slide them in place.

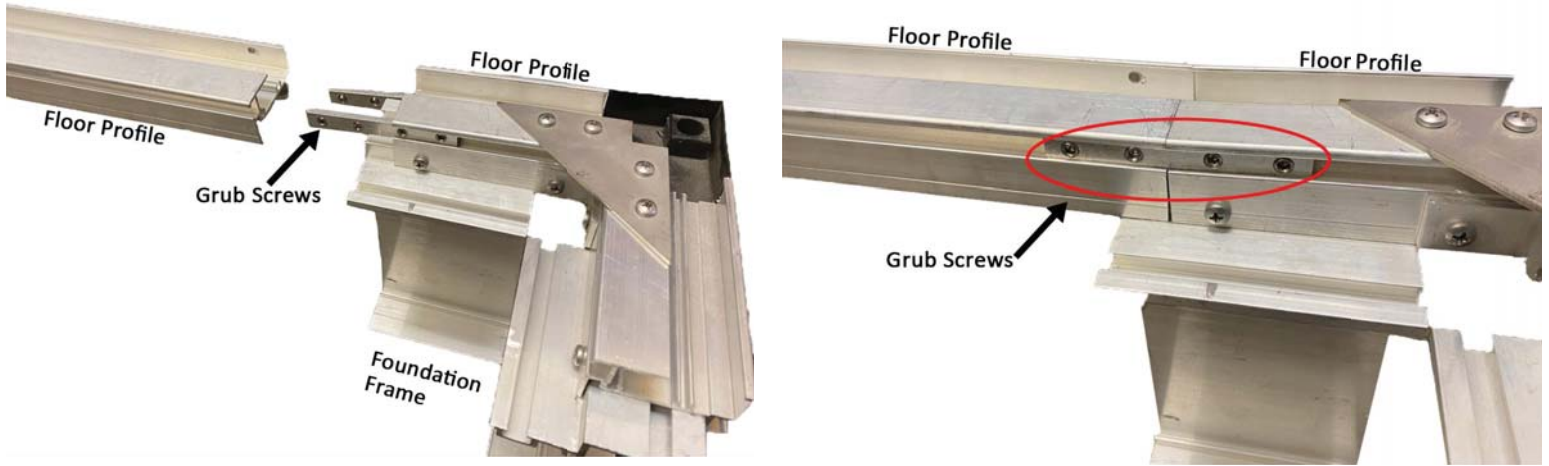



Connecting the Ridge Beam with Grub Screws



Extra Bracing for Riga XL 7/8/9 ONLY - bundled with the center curves

Assembly of the bracing

Pos.	Profile/part design	Description	Length [mm]	Quantity	Dimensions [mm]
		Bracing strut	1980	1 (XL7) 2 (XL8) 3 (XL9)	30x4
SM11		Hexagon head bolt M6 x 55mm		2 per bracing strut	
SM30		Nut M6		2 per bracing strut	

Remember during assembly! Place the pair of curves with the notches for the braces in the center of greenhouse. Then assemble as directed. Bracing struts and the corresponding curves should be near the middle. The XL7 comes with one strut, the XL 8 with 2, and the XL9 with 3.

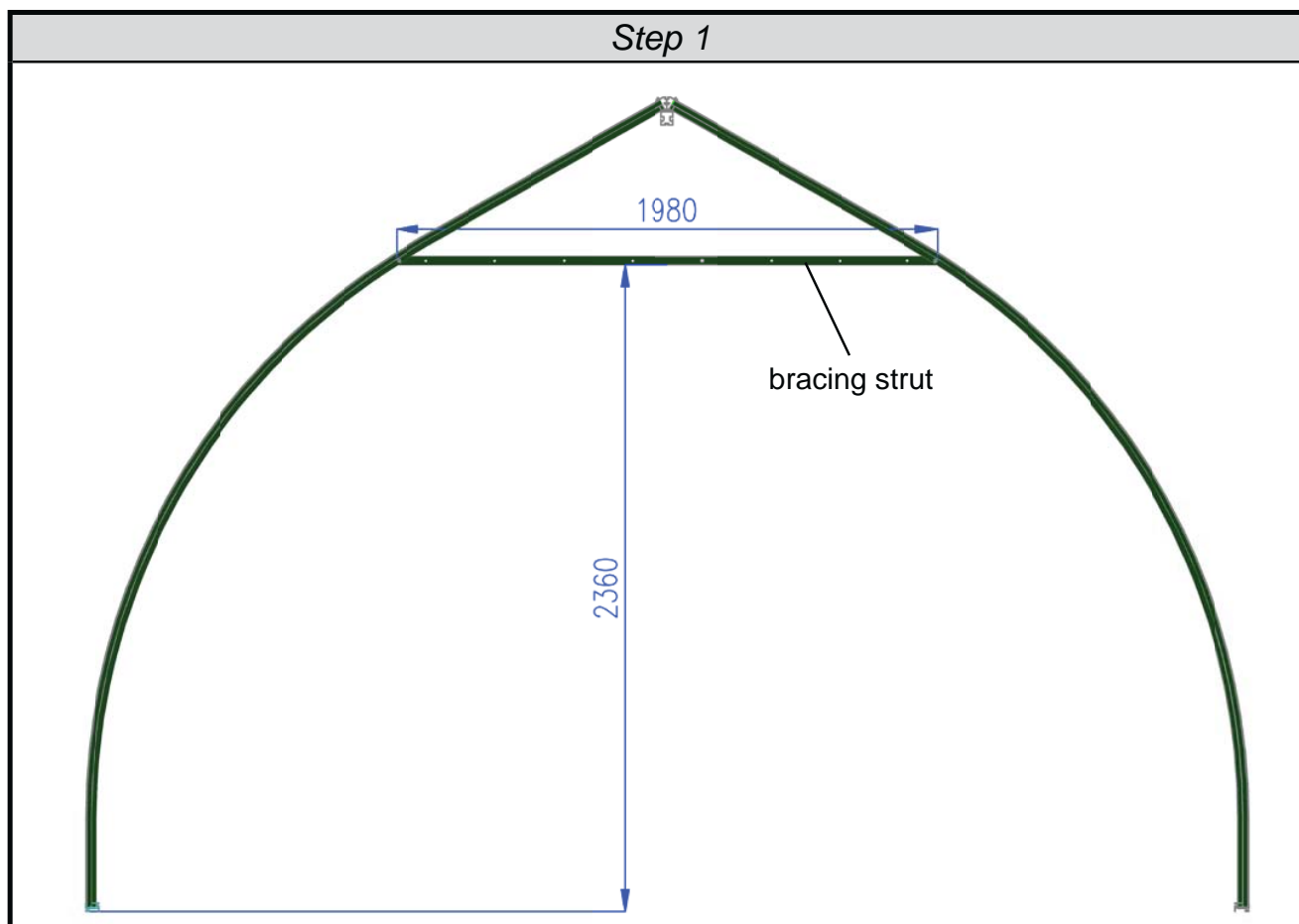

Extra Bracing for Riga XL 7/8/9 ONLY

Assembly of the bracing strut

Step 2

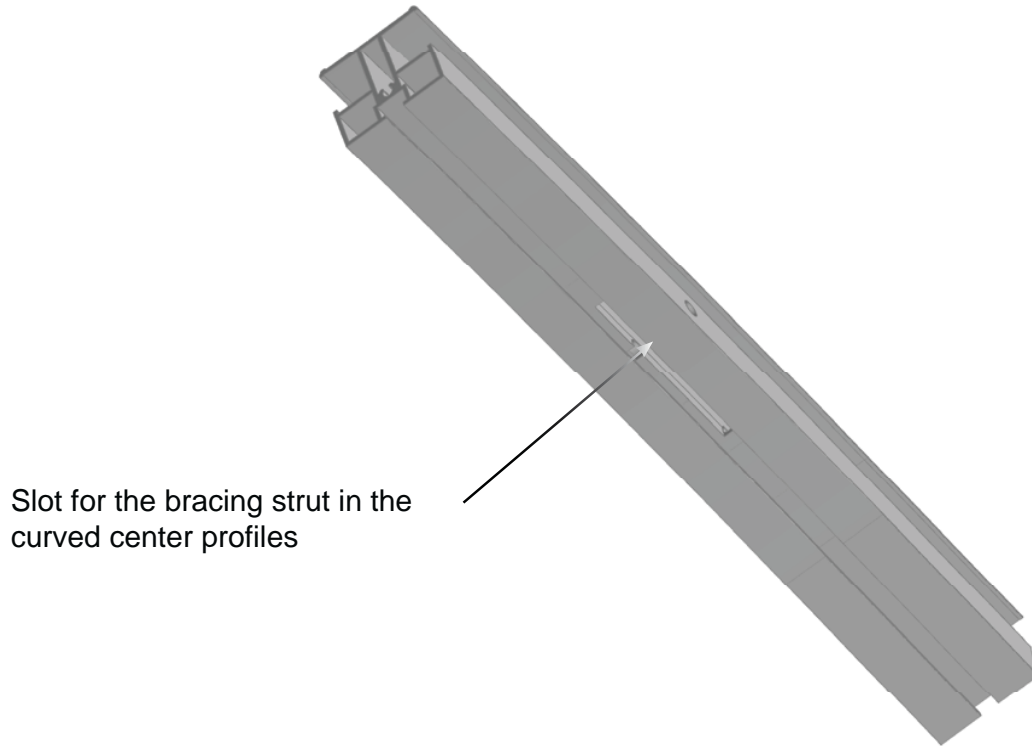

Step 3

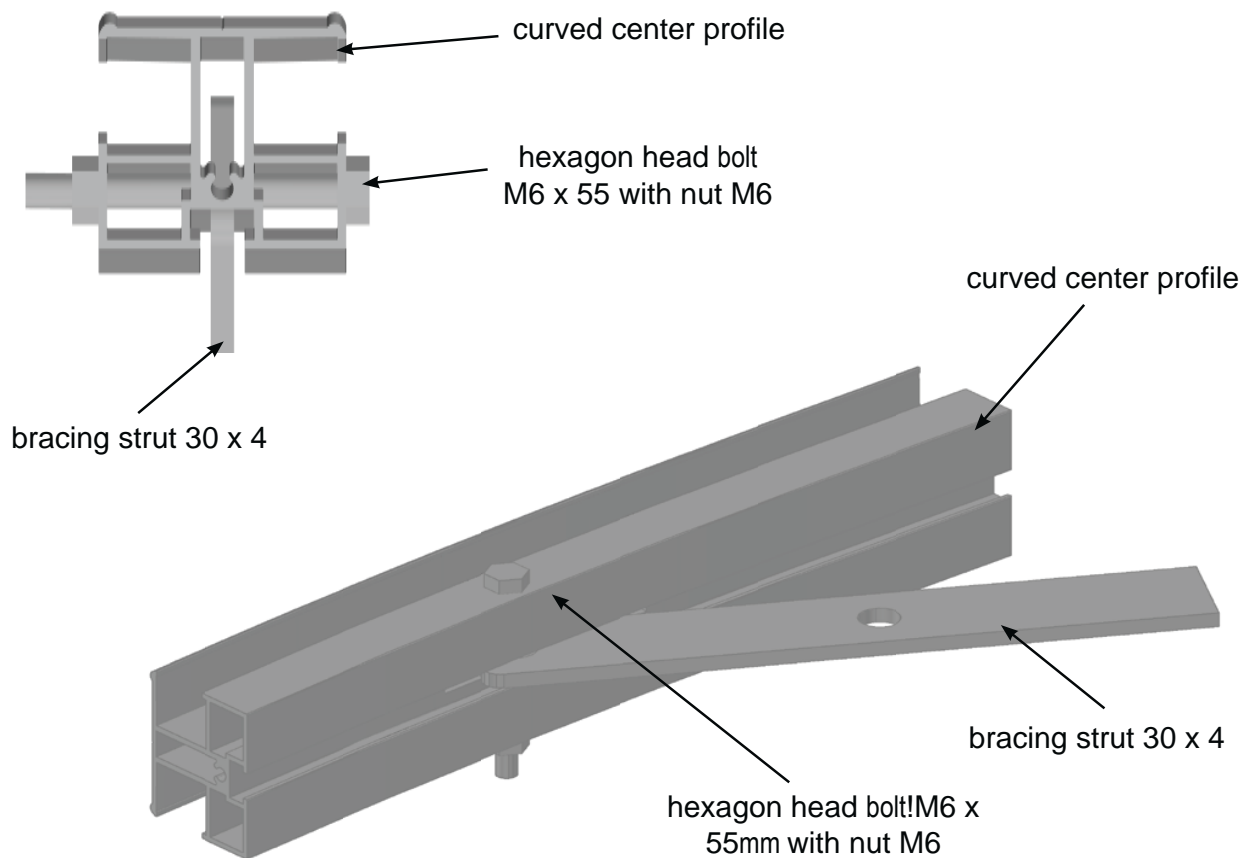

Attaching the foundation frame (optional accessory)

Profiles and hardware for foundation frame:

Note: For XL 7,8,9 models, the foundation frame will come in segments that will need to be connected with set/grub screw connectors. (see pg. 10) to make full lengths.

Profile/part design	Pos.	Description	Quantity/Measurement (mm)				
			XL 5	XL 6	XL 7	XL 8	XL 9
	6.1	Foundation frame profile for gable	2 4085	2 4085	2 4085	2 4805	2 4805
	6.2	Foundation frame profile for the sides	2 4859	2 5853	2 6848	2 7843	2 8838

Assembly of foundation frame

Note: Foundation frame profiles are shorter than the floor profiles!

1.

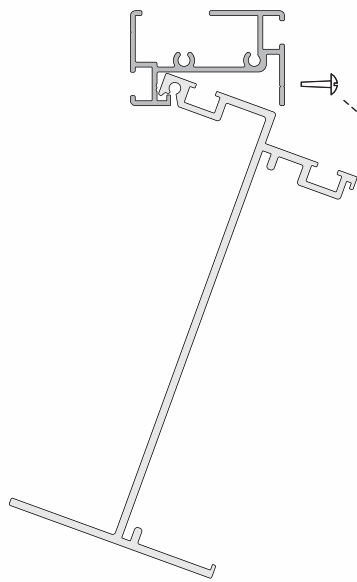

2.

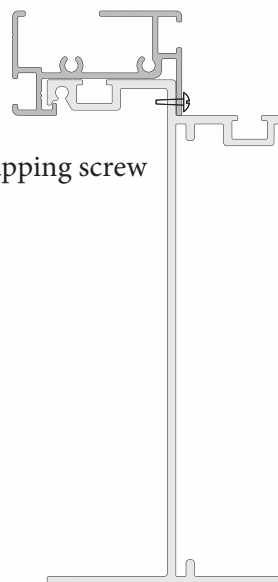

3.

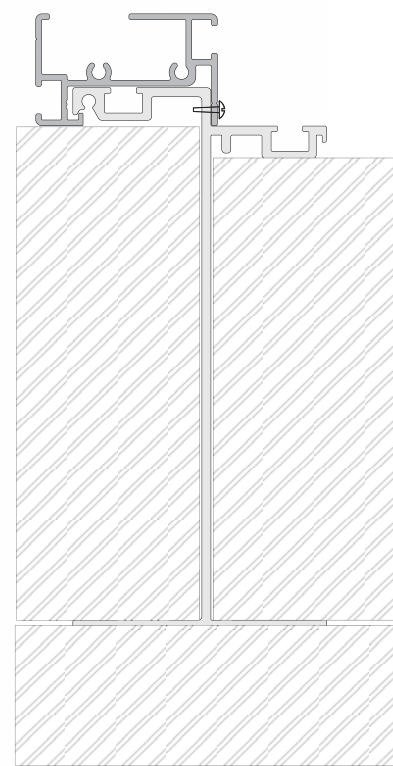



1. First hook the foundation frame into the soil profile, then rotate it into position.
Note: Make sure the foundation frame pieces are centered in the soil profile. The foundation frame will be shorter in length than the soil profiles.
2. Once in position use self tapping screws to secure the foundation frame to the soil profile. This is shown above. The self-tapping screws temporarily tack the floor profile & foundation frame together during assembly to make it easier to work with. Mounting brackets will be added later to secure it fully. Self-tapping screws will be found in the padded mailer envelope that was included with your greenhouse. If you cannot locate them - you may use any screw to temporarily tack the pieces together.
3. When the greenhouse has been fully assembled backfill both sides of the foundation frame with soil, or your media of choice.



Anchoring the greenhouse to your own foundation

Mounting brackets to attach base/floor profile to existing foundation.

Part design	Pos.	Description	Quantity/Measurement (mm)				
			XL 5	XL 6	XL 7	XL 8	XL 9
	6.7	Mounting brackets XL	16	18	20	22	24
	117	Hexagon head screw M6 x 12 + nut M6	64	72	80	88	96

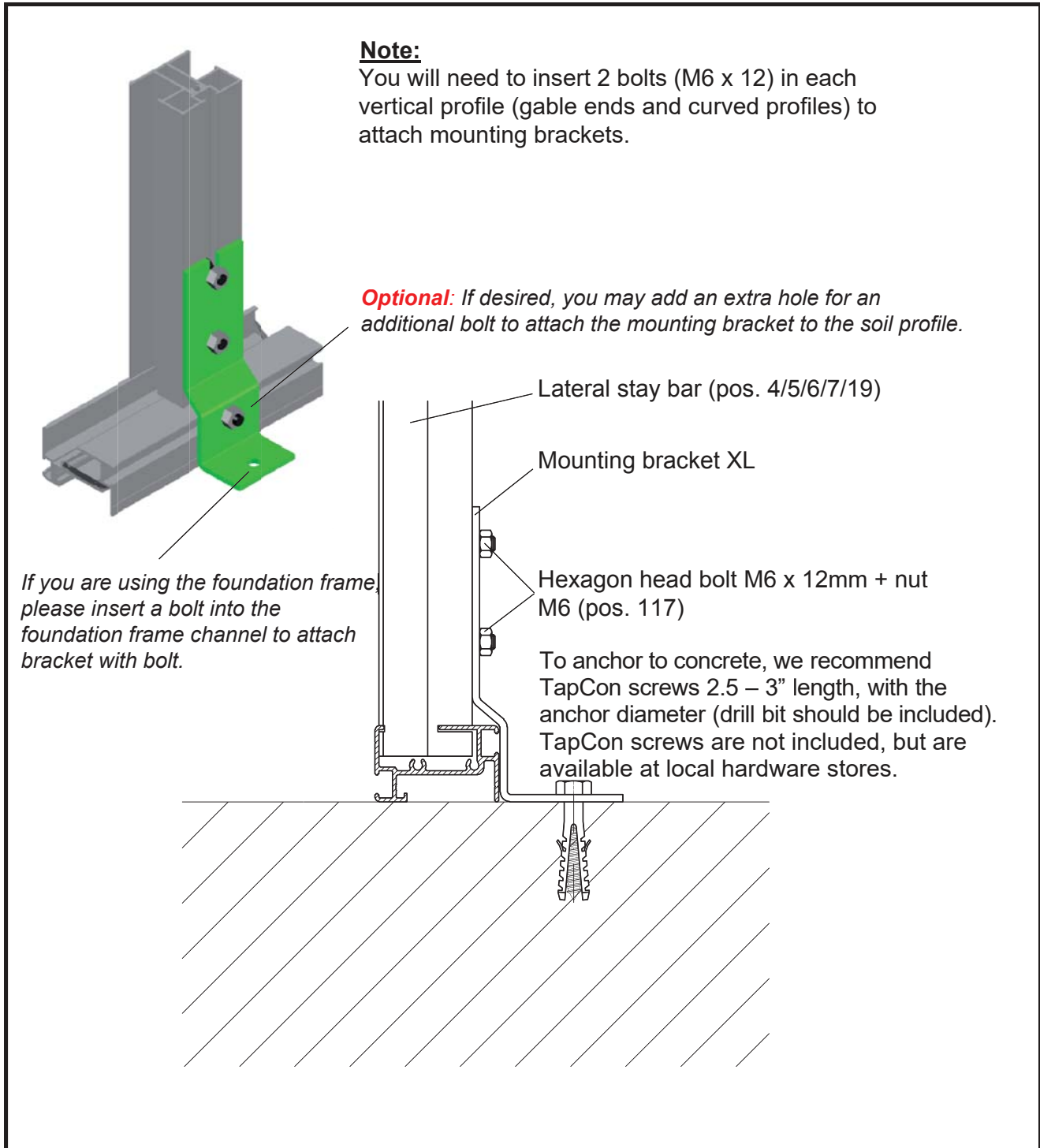

Foundation Plan Riga XL



Construction of your greenhouse with a concrete perimeter or strip foundation: If you did not buy a foundation frame, the greenhouse has to be erected safely by means of a perimeter/strip foundation. Please build this according to the dimensions in the chart below. You may also attach the greenhouse to a full concrete slab if desired - consider texture and drainage. The foundation must be even and level where the frame will sit. Fasten the constructed greenhouse with the supplied angle brackets and stainless steel TapCon (or similar) screws. We recommend 2.5 to 3" length with anchor diameter of 1/4". TapCon screws are not included and may be found at your local hardware with correct drill bit included.

Diagram below illustrates a sample strip foundation:

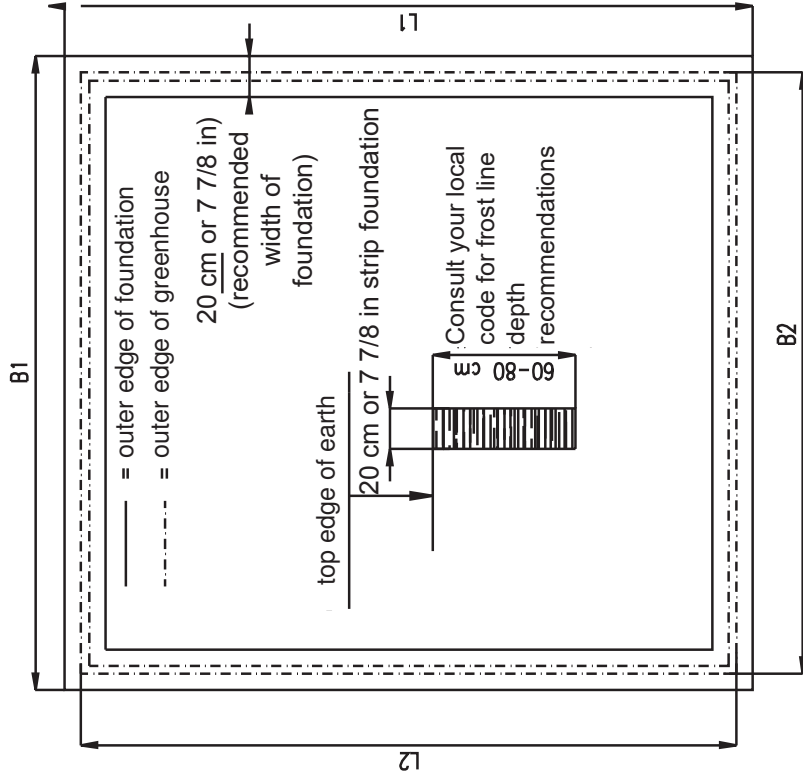

Door Extension Kit (Drop Door/Stem Wall): If you are placing your greenhouse on a stem wall, you will need a door extension kit and your wall must be 20" high. The XL greenhouses have a front and back door, which is centered on the gable wall. The rough opening for the door needs to be: 40 7/8" - better to make it 41". When building your stem wall, use the exterior dimensions of the greenhouse for the exterior dimensions of your wall - this will ensure your doors will open fully and connect with the door catch. The floor profile which will sit on your wall is 2" wide with L bracket anchor (1") for total of 3". Please be sure that the thickness of your wall allows for secure anchoring on the interior and meets local building standards.

	foundation		greenhouse exterior	
	B1	L1	B2	L2
Riga XL/5	442 cm 174 in	519 cm 204 5/16 in	425 cm 167 3/4 in	501 cm 197 1/4 in
Riga XL/6	442 cm 174 in	618 cm 243 5/16 in	425 cm 167 3/4 in	601 cm 236 5/8 in
Riga XL/7	442 cm 174 in	718 cm 282 11/16 in	425 cm 167 3/4 in	701 cm 276 in
Riga XL/8	442 cm 174 in	818 cm 322 1/16 in	425 cm 167 3/4 in	801 cm 315 3/8 in
Riga XL/9	442 cm 174 in	918 cm 361 7/16 in	425 cm 167 3/4 in	901 cm 354 3/4 in

Gable Assembly - Start with the assembly of the gables - front and rear gables are identical.

Warning: If you are using the foundation frame, it has to be attached to the base profiles **FIRST!** (Page 8)

Step 1

Important: Look for the circle and note of 1x, 2x, etc. for insertion of bolts. during assembly!

Ensure top angles of vertical profiles are correct!

Attention: Before assembly, insert required M6 x 16 (pos. 107) in floor profile channel. Insert 2 bolts M6 x 12 (pos. 117) into vertical profiles for mounting brackets (pos. 6.7).

Align vertical profile channels with holes in floor profile

Step 2

Push glazing into floor profile first, then slide into vertical profile.

Phillip head screw 4,2 x 13 (pos. 111)

Step 3

Crossbar (pos. 8)

Step 4

View from inside

Attention: Insert noted quantity of bolts M6 x 16 (pos. 107) in profile groove before assembly.

Attach the T-connector (pos.103) with inserted bolt m6 x 16 and nut M6.

Step 5

View from inside

Attention: Insert noted quantity of bolts M6 x 16 (pos. 107) in profile groove before assembly.

Note angles at the top of vertical profiles when attaching!

Attach plastic corner connectors (pos. 100) to floor profile ends

Step 6

View from inside

Attention: Insert noted quantity of bolt M6 x 16 (pos. 107) in profile channel before assembly

Connect Crossbar using T-connector (pos. 103) and inserted bolt M6 x 16 and nut M6 (pos. 107).

Step 7

View from inside

Connect Crossbar (pos. 8) with straight connector plate (pos. 101) and inserted bolts M6 x 16 (pos. 107) and nuts M6.

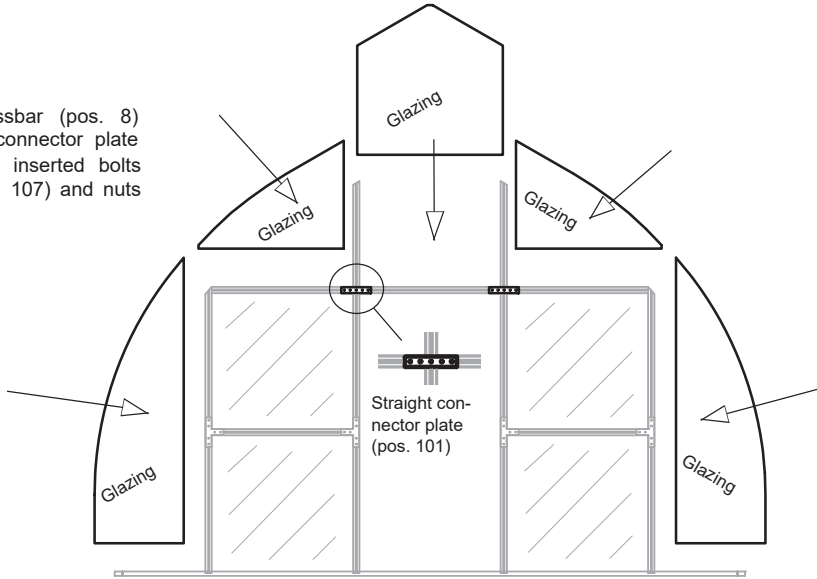

Step 8

View from inside

Attention: Insert noted bolts M6 x 16 (pos. 107) in profile groove before assembly.

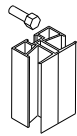

2x in crossbar (pos. 8) on left AND right

* 2x in vertical profile middle (pos. 4+5) - on left AND right

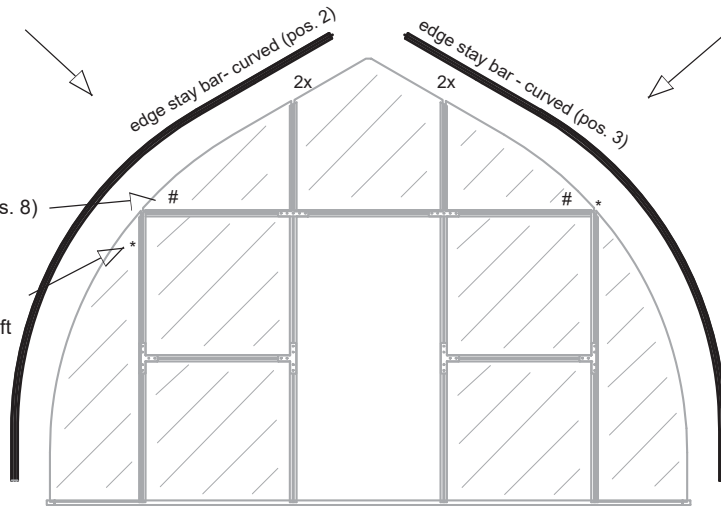

Step 9

View from inside

Slanted connectors are attached to edge stay bar with self drilling screws 3,5 x 13 (pos. 117).

Use "fitment tool" to properly space edge curves until attached to the ridge beam. Fitment tool looks like a short section of the ridge beam.

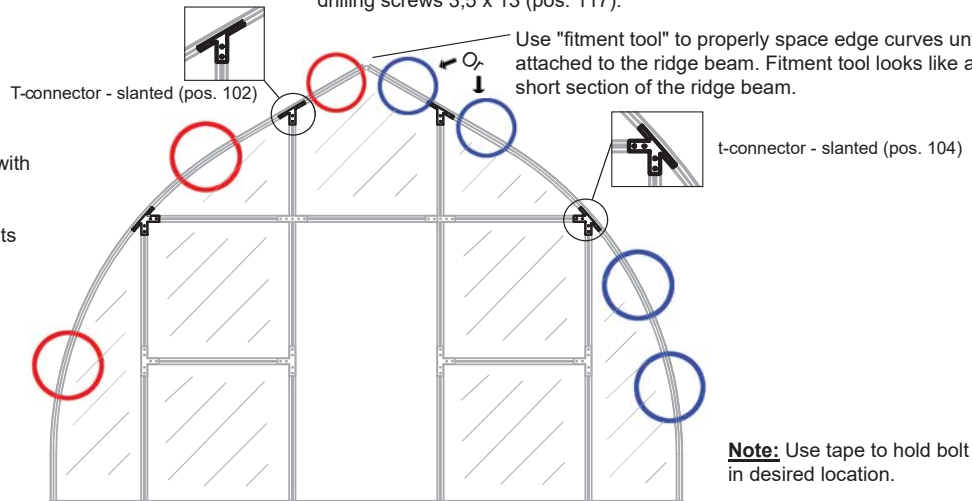

Edge stay bar (pos. 2 + 3) with t-connectors - slanted (pos. 102 and pos. 104) are connected with inserted bolts M6 x 16 and nut M6 (pos. 107) on the crossbar and vertical profile.

The t-connectors are connected with self drilling screws (pos. 117) on the edge stay bar.

Note: Use tape to hold bolt in desired location.

Recommended Placement Height: Insert bolts into channel on edge curve to attach your lateral supports. Placement height may vary and will determine the height of your shelves if you have them. Red circles mark the lateral support location on the side with no shelves, blue marks the side with shelves. You can pick which side you want the shelves to go on.

Side Wall Assembly

Warning: If you are using the foundation frame, it has to be attached to the floor profiles **FIRST!** (Page 8)

Step 10

Attention: Insert bolts M6 x 16 (pos. 107) in profile groove before assembly.

floor profile connector (pos. 105)
+ bolt M6 x 16
+ nut M6 (pos. 107)

1x

inside

1x

Insert 2 bolts (pos.107) into each middle vertical profile for the mounting brackets (pos. 6.7).

Put in the floor profiles (pos. 16) on the corner connector.

Step 11

Attach roof beam to back gable with endcap/cover plate (pos. 114) with Philips head screws 4,2 x 13 (pos. 111). The roof beam end will slide into slot on edge curves until flush with back of greenhouse.

roof beam pos. 26

IMPORTANT!
End of roof beam must be supported

Front gable will assemble the same way later!

Step 12

Insert the glazing panel on each side - they will bend. Insert first into the floor profile, then into roof beam. Usually, this will take 3 people.

Step 13

Recommendation: Begin attaching lateral supports at this time (pos. 20/21/22). This will help stabilize the structure and assist with proper spacing. (see step 18)

Curved center profiles (pos. 19) enlarged!

Insert curved center profile (pos. 19) top into roof beam and below into floor profile. Push straight on up to glazing and „thread“ pane.

Step 14

Slide in subsequent glazing and curved center profiles. Consider Roof window position during this time.

Apply silicone between window crossbar and the curves to prevent water leakage.

Attach window crossbar connector plate (pos. 115) on inside with bolt M6 x 12 and nuts.

Attention: For roof window installation, insert one bolt M6 x 16 (pos. 107) in each curve adjacent to window before assembly. In cross bar under window(pos. 25), insert 3x M6 x 16.

Step 15

Attention: Insert bolts M6 x 16 (pos. 107) in profile groove before assembly.

1x

1x

Push glazing and curved center profiles together completely. Consider your roof window placement while doing this!

Step 16

floor profile connector (pos. 105)
+ bolt M6 x 16
+ nut M6 (pos. 107)

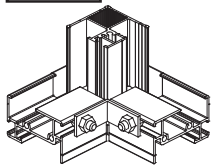

Attach assembled front gable in same manner as rear gable.

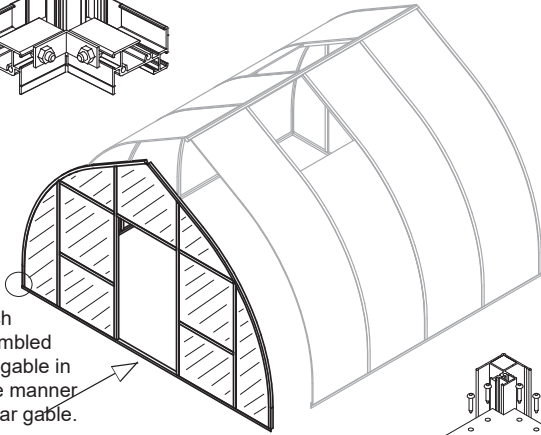

Attach floor profile corner connector (pos. 116) with screw 4,8 x 16 (pos. 113).

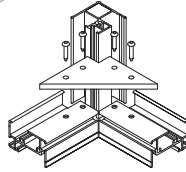

Step 17

Attach doors with hinge hardware.
Roof windows slide into the roof beam from the end. Note diagram below for proper insertion.

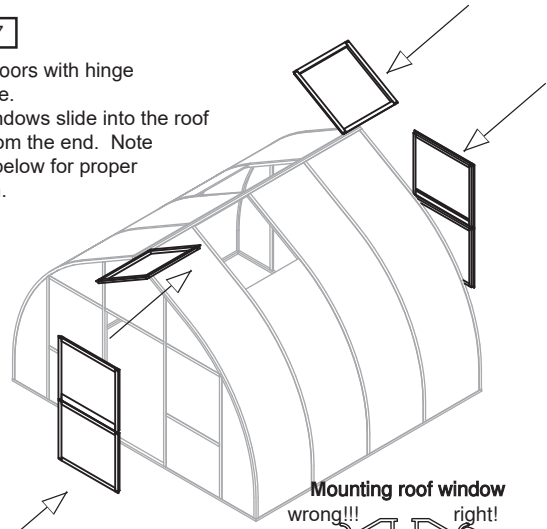

Mounting roof window wrong!!! right!

*See window assembly page for additional information.

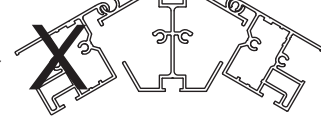

Step 18

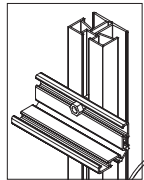

For illustration detail the panes are shown cutaway.

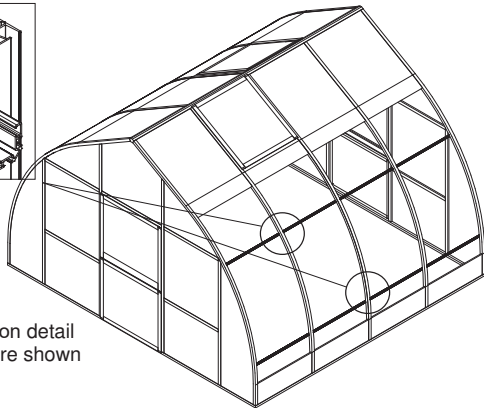

The lateral supports (pos.20/21/22) are attached to all the curves on the inside of the greenhouse with bolts M6 x 16 and nuts M6 (pos.107) and washer (pos.108).
The lateral supports are also back profiles for the optional tables and shelves. (See separate assembly instructions!)

Then you should look for:

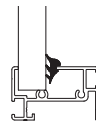

Press Insulation seal 6 - 8 mm in between the floor profile and glazing on all 4 walls on the inside of greenhouse.

Attention: Please compress the seals, because it contracts in cold weather.

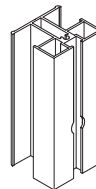

IMPORTANT!

Hexagon bolts can be inserted later into most of profiles through a special „hole“ in the channel. If there is no hole you can drill one yourself.



T-sealings (pos. 126, 138, 153) for all doors and windows (altogether ca. 26 m).

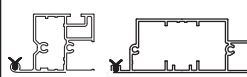

Attention: The t-seal goes only on 3 sides of the roof window - not the top bar profile.

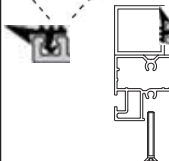

Attention: The t-seal must be inserted first in the top profile of the bottom door before assemble the rectangular tube.

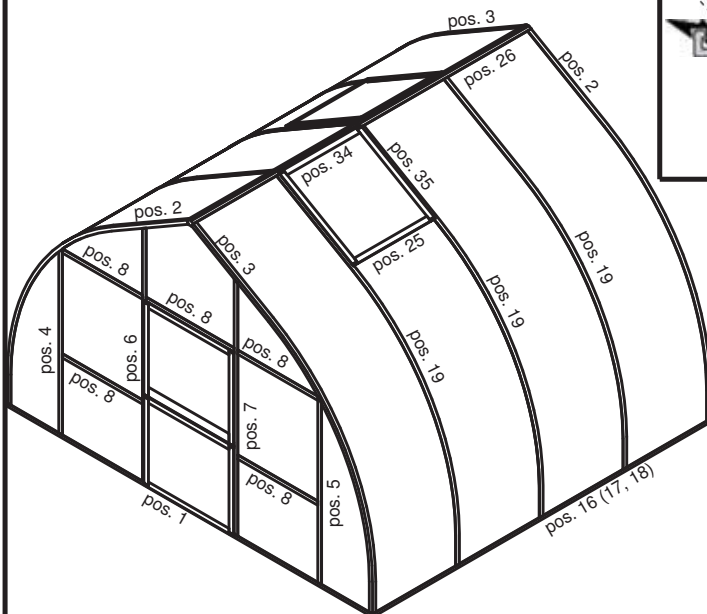

All exterior horizontal surfaces should be sealed with neutral cure silicone. This will prevent moisture from seeping into the channel and prevent excessive condensation in the polycarbonate panels. Please note that some condensation is natural at certain times of the year and will often burn off once the sun heats the air. See p. 28 for details.

Roof Window Assembly

window profile (pos.34)
(No T-seal in this profile!)



plastic corner connector (pos. 127)



window profile (pos. 35)



First, connect three profiles with screw 4,2 x 60 (pos. 112), then insert glazing and attach fourth profile.

Important!
Neutral cure silicone must be used to seal the corner connectors/caps (pos. 127) where they meet the aluminum profiles, as well as all around the window glazing where it meets the aluminum. This is to avoid any penetration of humidity.
T seal will be inserted in the small groove

Attention:
Insert 2 bolts in the groove of the bottom profile - for window opener!

Phillips head screw 4,2 x 60 (pos. 112)

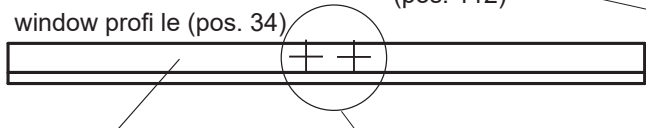

window profile (pos. 35)



Attach the Sash Lock (pos. 136) with Phillips head screw 3,5 x 22 (pos. 141).



silicone where poly meets aluminum frame

Polycarbonate

silicone where poly meets aluminum frame

T-seal

window profile

Greenhouse framing

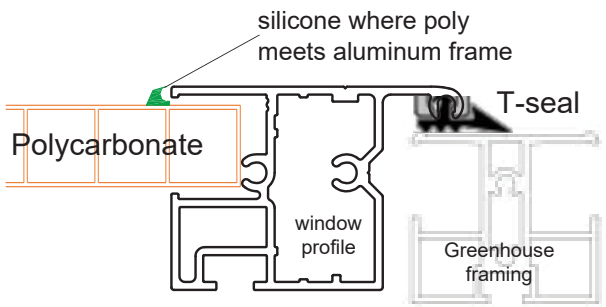



Automatic window opener

mounting roof window

Incorrect!!!

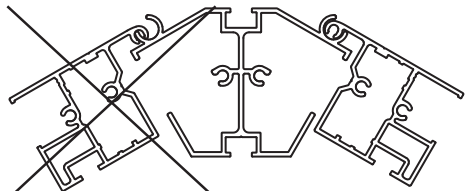

Correct!

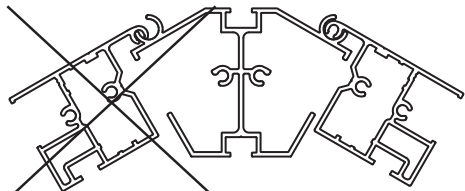

The roof window is installed by sliding it on from the end of the roof beam as shown to the left (like a ball and socket).

If you are struggling with installation of the roof window:
The top ridge of the window slides through the very narrow channel on top of the roof beam. Spray both the channel and the top of the window bar with white lithium grease (rub it on). While standing high up on a stable stepladder/platform, hold the window at about a 45° angle and slide it in from the very end of the ridge beam - it needs to remain perfectly straight. Once inserted, you can move the window up and down (but only by about 20°) and as you move up and down you push it down the channel to your openings.

Automatic Window Opener

1	opener frame
2	pressure cylinder
3	cotter pin
4	mounting plate window profile
5	mounting plate cross bar

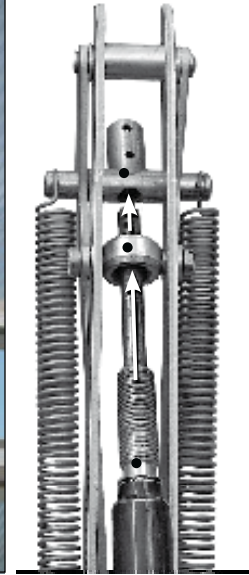
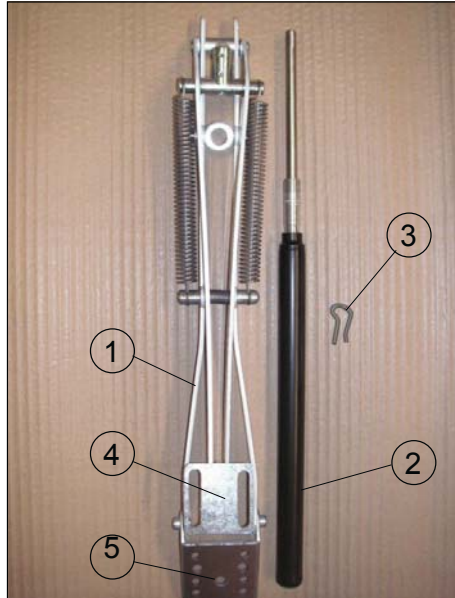
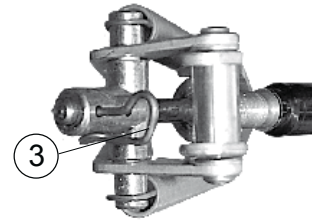

Auto Opener Installation

1. Check whether the greenhouse window can open and close freely and unhindered.
2. Install the opener with the mounting plate (4) in the center of the lower roof window profile (pos 4.2)
3. Secure the cylinder by lining up the hole in the piston with the upper hole in the T-coupling, then insert the cotter pin.
4. Install the mounting plate (5) in the center of the cross bar(pos 3.2) using the middle hole in the mounting plate(5)
5. Attach the opener frame (1) to the mounting plate (5) please see bottom of next page for correct placement to avoid bursting your piston. Open the roof window until the threads of the piston (2) engage the threads of the opener frame (1). Thread the piston (2) half way into the threads in the opener frame (1). If you are struggling to thread the piston in - place it in the fridge for 15 minutes then try again.

Adjustment:

Let the opener acclimate to the greenhouse for 3-4 hours before you make adjustments.

For earlier engagement and a larger opening, turn the cylinder clockwise. For a delayed engagement and a smaller opening turn the cylinder counter clockwise. Make sure you don't back it out too far. For opening engagement advance/delay one full turn is about 1 degree Fahrenheit. Please keep in mind that greenhouse temperatures can vary and windows can have different opening tolerances.

Winter-usage:

When the temperature decreases and window opening is not desired - or when heating the greenhouse:

1. Either unscrew the cylinder from the cylinder housing so the piston is hanging from the cotter pin and cannot open the window OR pinch the arms of the opener near the mounting plate (5) to release the opener. The cylinder can be left hanging in this position over the winter.
2. Use a sash lock to lock the window shut for the winter so it cannot blow open.

Required Maintenance:

Two to three times a year, check to make sure the piston shaft and cylinder threads are greased and move freely. A dab of light oil such as WD40 or olive oil on the piston shaft and the cylinder threads will be sufficient. Failure to do so could render your opener inoperable.

Riga Greenhouse Window Auto Opener Correct Installation

In the correct position, the opener is sitting parallel to the window, which means that it will not demand a lot of pressure from the cylinder when the opening starts. Before fitting a new cylinder to the openers, you must check that the window can open freely right from the start. If not you must change the position of the aluminum profiles.

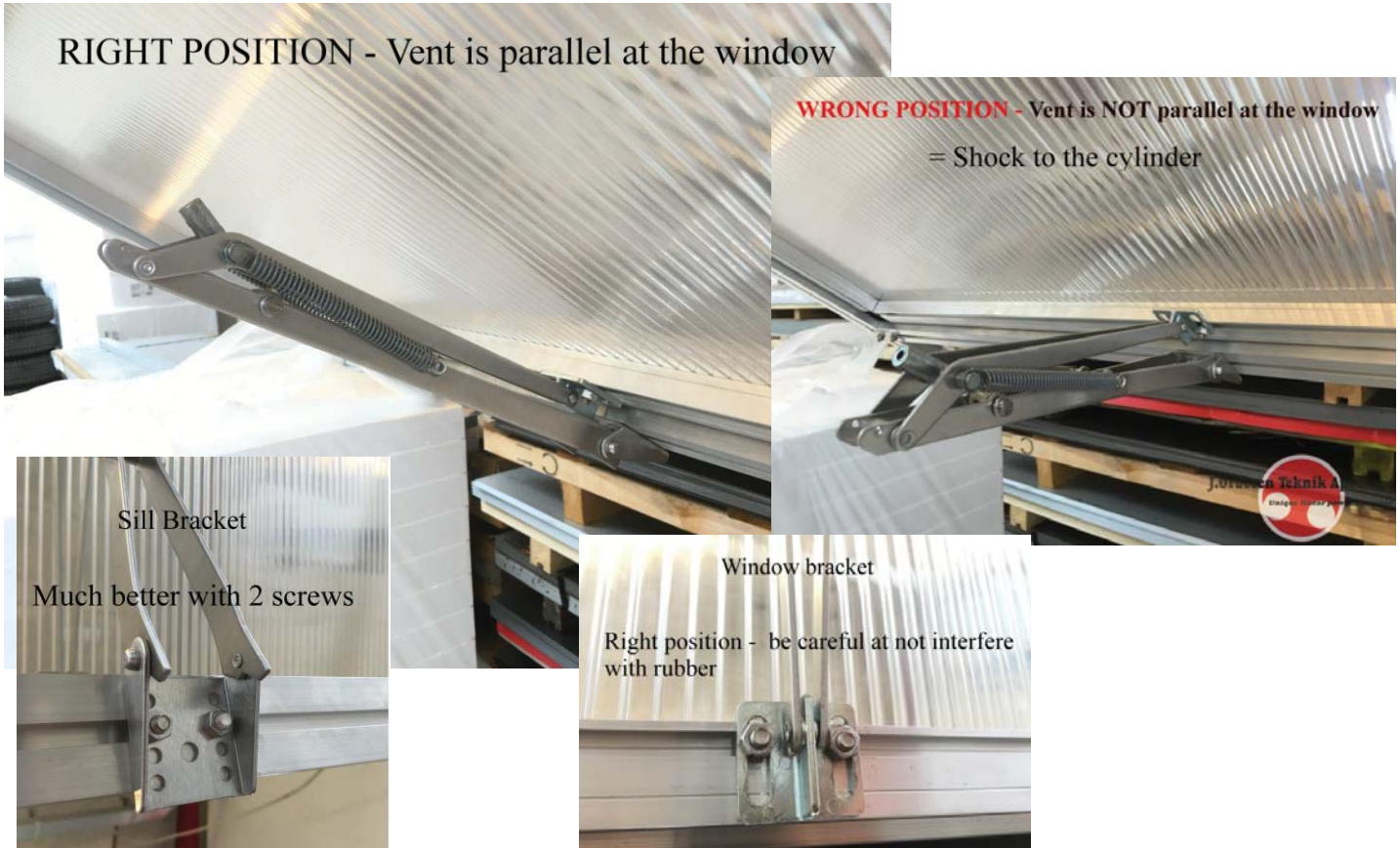

When placing the "quick-release" arms into the sill bracket, be sure that both points are on the same side of the bracket. If they are not, the opener will not move freely when the pressure builds and your piston will burst. This is not covered under warranty. See pictures below.

INCORRECT:

Note that point is OUTSIDE the bracket



CORRECT:

Note that point is INSIDE the bracket



Roof Vent Recommendation for High Wind Areas

If you get strong wind gusts, we recommend protecting your roof vents and openers with restraint cables. Roof vent restraints can be purchased from Exaco Trading (US distributor of Riga's) or can be made, they are not a standard part from the Riga manufacturer.

Two restraints are used for each window; one on each side of the window. Install each loop on bolts inserted into the channel and top with a washer and nut. Position the restraint as illustrated and adjust as needed to avoid interference from the crossbar as the window is raised and lowered.



You can make your own restraints from $\frac{1}{16}$ " stainless wire rope, stranded 7x19 for maximum flexibility. Overall length should be about 16". When installed near the crossbar, they will limit the window opening to less than the safe extents of the hinge and window opener, but greater than the maximum thermal extent of the opener. More important than the exact length of the restraint is a close length match for each window's pair. If you are not equipped to swage the binding sleeves you can use wire rope clamps.



Mounting divided revolving door - at the bottom

View from outside

Place the profiles on a flat surface according to the diagram below (a cardboard surface works well).

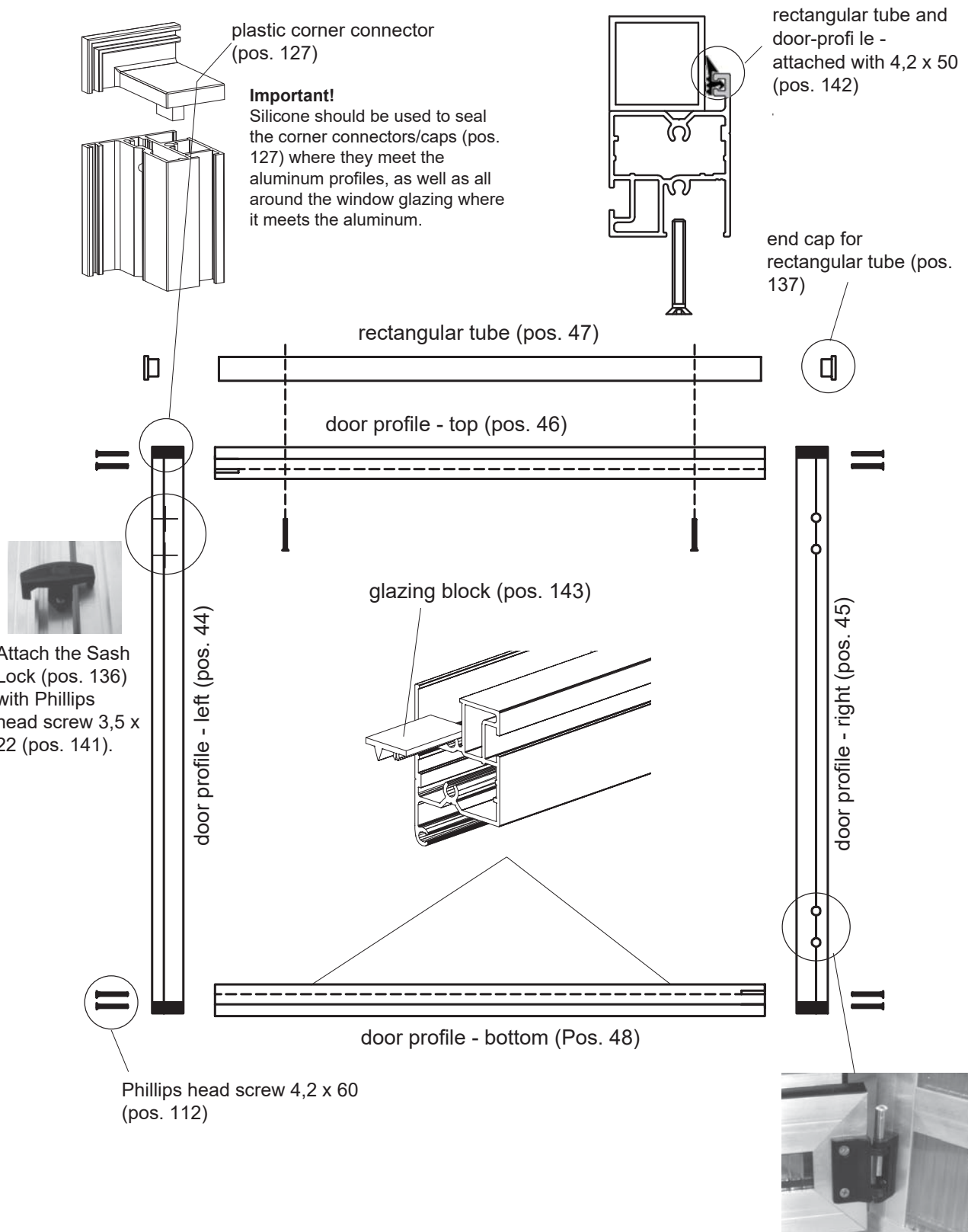

* **Note:** The rubber seal is in one bundle for all doors and windows. Cut accordingly please.

Mounting revolving divided door - top

View from outside

Place the profiles on a flat surface according to the diagram below (a cardboard surface works well).

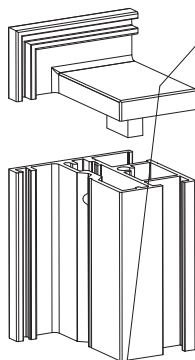

plastic corner connector (pos. 127)

Important!

Silicone should be used to seal the corner connectors/caps (pos. 127) where they meet the aluminum profiles, as well as all around the window glazing where it meets the aluminum.

phillips head screw 4,2 x 60 (pos. 112)

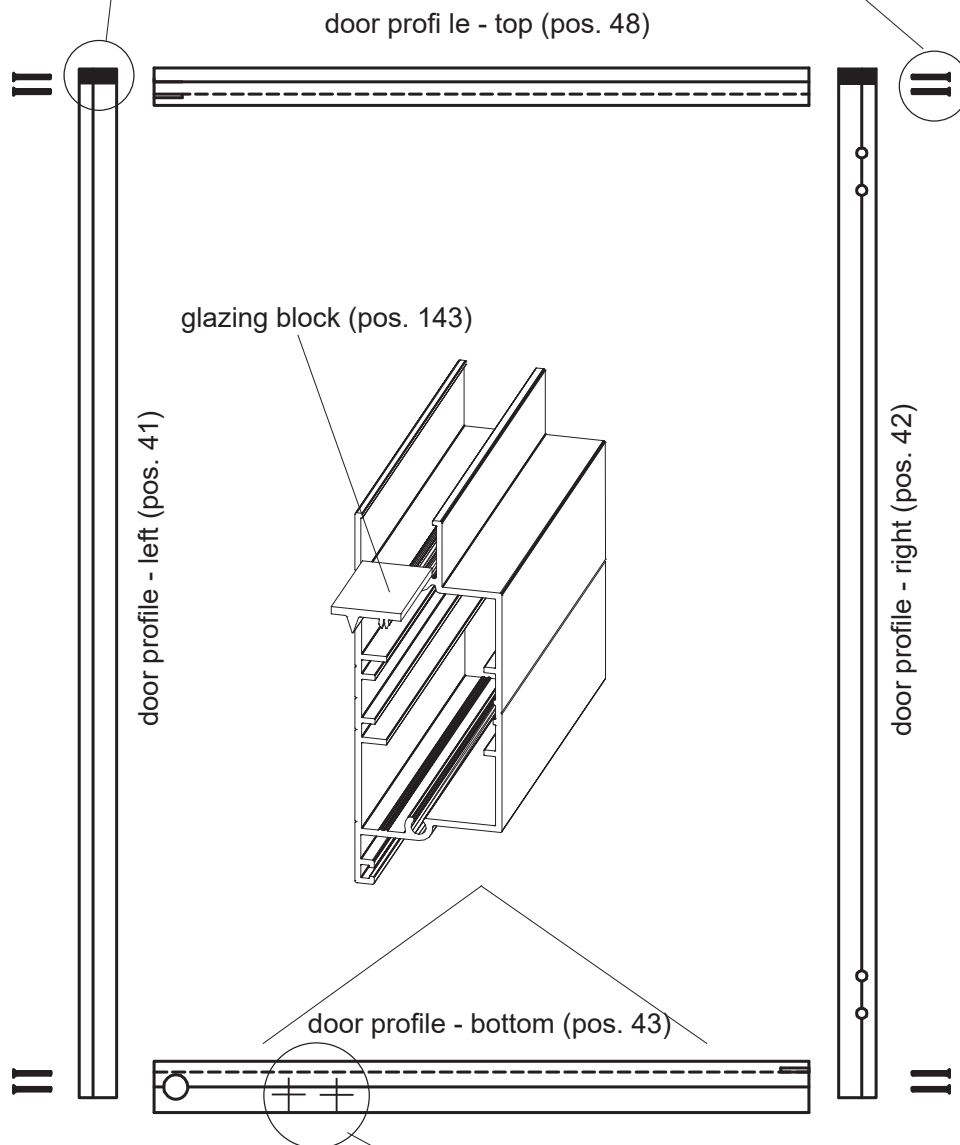

Attach the Sash Lock (pos. 136) with Phillips head screw 3,5 x 22 (pos. 141).

* **Note:** The rubber seal is in one bundle for all doors and windows. Cut accordingly please.

Assembly instructions for lockable handle

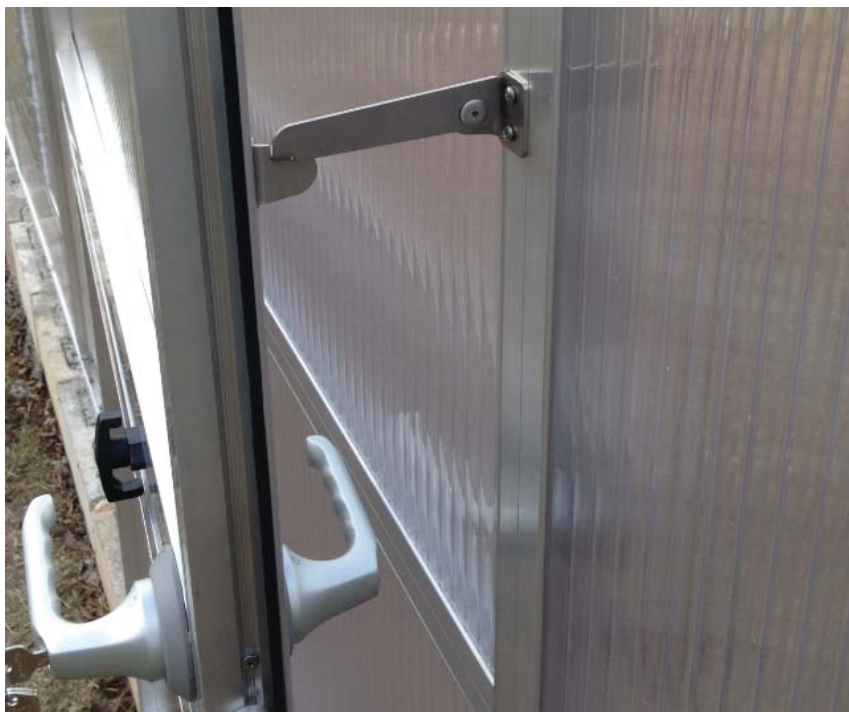
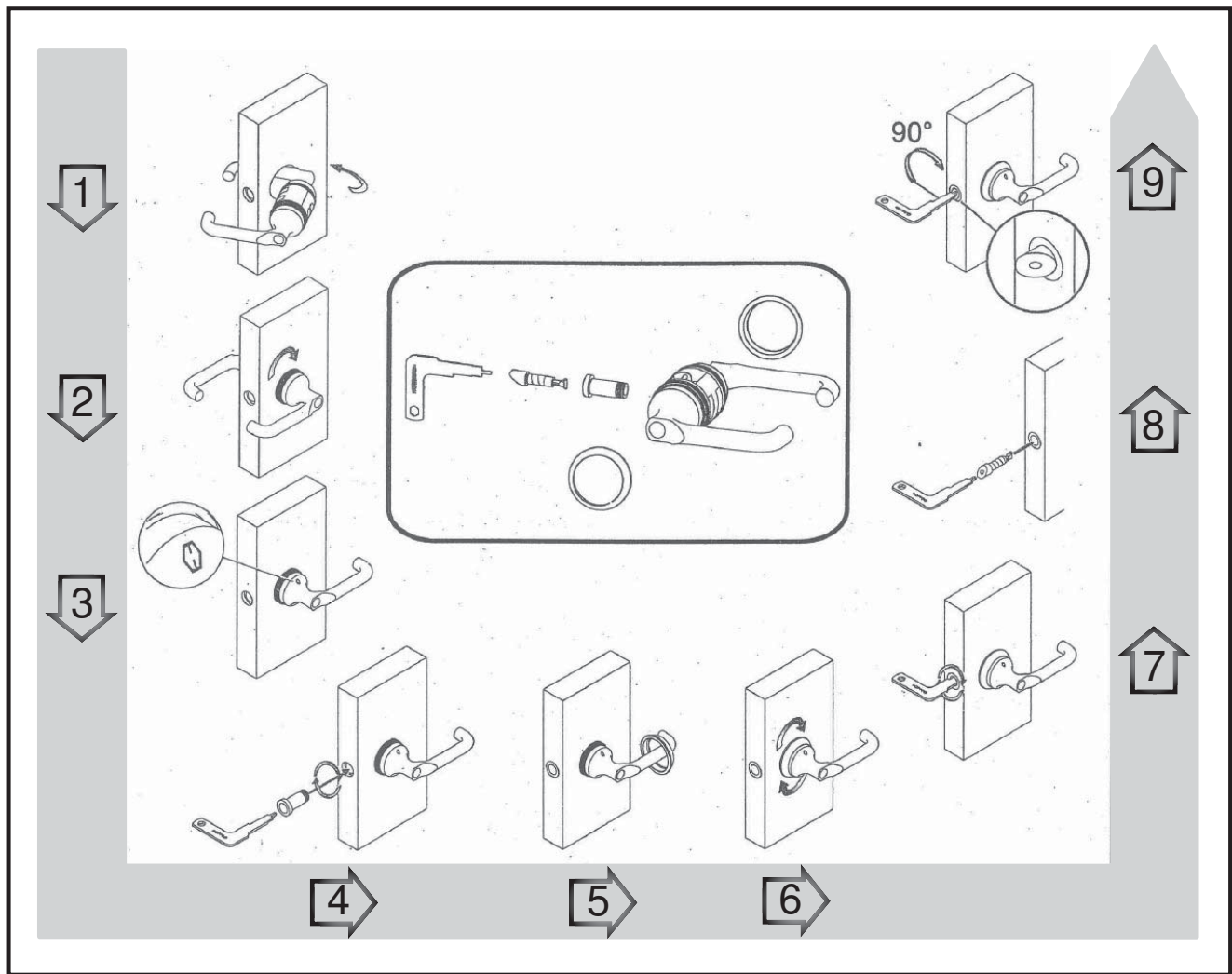

Riga XL Metal Door Holder

After the door is assembled and installed, you may place the door holder as seen to the left. You may use self-tapping screws or predrill a small hole.

SEALING WITH SILICONE

Question: Is it necessary to seal the greenhouse or greenhouse glazing?

We strongly recommend sealing the exterior horizontal transitions from the glazing to the aluminum profiles with neutrally cure transparent silicone. This will help keep water and dirt from the glazing channels. In the diagram below, the dotted lines show the areas that should be sealed.

In the long term the greenhouse has a better appearance. The tendency for algae formation in this area decreases tremendously.

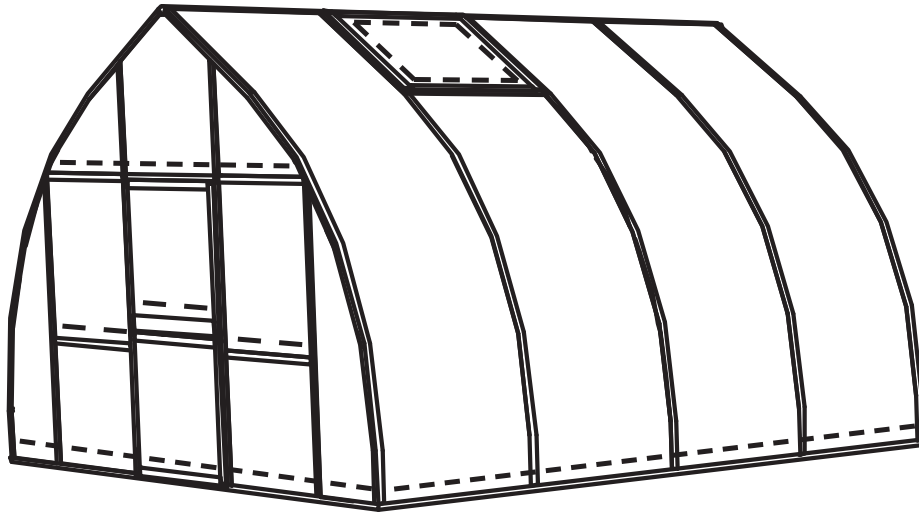

Humidity/water can still appear within the polycarbonate glazing channels however, due to local weather changes. The polycarbonate glazing is not "steam-diffusion-tight", meaning humidity in vapor form can penetrate into the sheet. This is a purely optical disadvantage which cannot be avoided. The sheets will not suffer any damage from this.

Attention:

Only neutral cure silicone should be used due to possible stress cracks in the polycarbonate glazing. Exaco has Boss 399 Silicone, or GE Advanced Silicone 2 is readily available at most local home improvement stores.

Cleansing and maintenance:

Clean the greenhouse with water and a soft cloth or soft brush (ex. car wash brush) if necessary. If you feel you need soap, we recommend a gentle dishsoap, such as Palmolive.

We wish you happy gardening and enjoyment of your Riga greenhouse! If you need any assistance, please reach out to Exaco at 877-760-8500 or customerservice@exaco.com.

All our statements are based upon many years of experience and are drawn up to the best of our knowledge and belief and they do not cover any legal entitlements in case of any possibly arising events of claim.

Auto Opener and Piston Troubleshooting:

How does the auto opener and piston work?

The black piston cylinder is filled with a mix of oils that naturally expand around 73 degrees. As the oil expands, it will begin to push out the rod of the piston and open your window. The springs and the weight of the window will pull it shut when the temperature drops. Please note that if the piston is not in the opener assembly, it will not retract on its own (it is the pressure of the springs which cause the retraction).

Here's a few things to check for on the pistons:

Is the piston moving at all? To test, remove the piston and place in ice water for 15 minutes, push the rod in and measure the length. Place in hot water for 15 minutes (above 90 degrees). Measure the distance – did the rod push out? If so, your piston is working.

Does the piston rod move in and out smoothly? The manufacturer recommends oiling them regularly (2 to 3 times/year) with a light oil such as olive oil or WD40. Sometimes oiling them will help get them moving if they are stuck.

Were the pistons ever under pressure? If the opener and piston are attached while there was a weight or lock/sash lock holding the window shut, the piston can burst open and release the paraffin oil inside. This can also happen if they are stored in a tight container that doesn't have enough room for them to expand. If a piston has burst, this is usually evident by visible oil, a gash in the side of the piston – or the rubber stopper in the end might have popped out.

Does everything look intact on your opener?

- There is a cast metal T piece that occasionally breaks – see pictures to the right.
- Sometimes the arms of the opener are “torn” or twisted. This can happen when a huge wind gusts pulls the window further than the opener can handle (can be prevented with wind cables) OR someone thought the opener was a handle to open the window and has pulled on the piston to try to open the window.

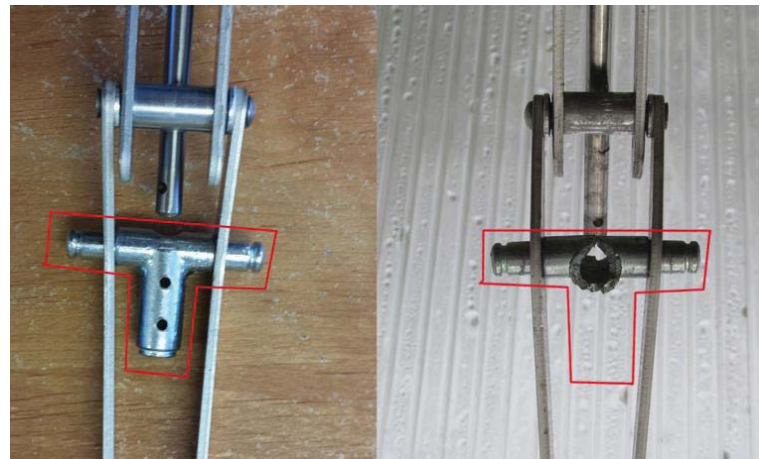

If you are installing in a Riga greenhouse, please check the angle at which the actual opener is installed. See the next page regarding the opener installation in a Riga greenhouse. If installed incorrectly, pressure builds in the piston and can make it difficult to open the vent. This can also make pressure build up in the piston until the window suddenly “pops” open – or if you slightly push the window it opens suddenly.

If you are unsure of any of the above, a photo can help us diagnose the issue. Please send us photos of your opener installed with the piston threaded into the holder. Also include a photos of the imprint near the end of piston, which will have the manufacturer's name and a date stamped into the black sleeve. We need this to file a warranty claim with the manufacturer and replace your piston.

How does the Cylinder warranty work?

1) Coverage

Your cylinder is covered for 2 years from the year that is stamped on the cylinder.

2) How to test if your cylinder is defective or not?

- 1) Prepare a bucket of hot water and a bucket of cold water.
 - 2) Put the cylinder in the bucket of cold water for around 10 minutes and then push the piston pin in as far as it will go.
 - 3) Then put the cylinder in the bucket of warm water. Observe if the piston pin comes out (it can take around 10 minutes before something will happen). If the piston pin doesn't come out by approximately 8 cm then it means that the cylinder is defective and you can take advantage of your warranty.
-

3) Leaking cylinder?

Is covered during the warranty period.

4) Cracked cylinder or rubber plug coming out the end?

An overloaded cylinder as a result of incorrect installation/usage of auto opener is normally not covered by the warranty. Individual treatment each time. See example to the right.

The cylinder can be overloaded due to incorrect installation. See our installation videos on www.orbesenteknik.com for the correct installation procedure.

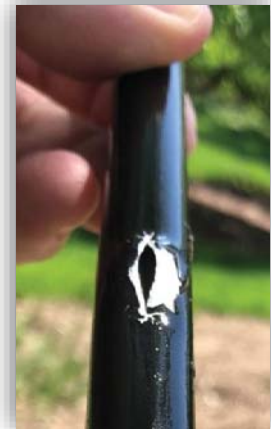

5) Should you send the damaged cylinder back to us?



No, we only need you to send us a picture, of the cylinder where we can see the mark "ORBESEN TEKNIK and YEAR" on the cylinder, along with the damage and an explanation of occurred. Please include your address so that in a case of warranty coverage we can send a new cylinder. [Send to helpdesk@exaco.com](mailto:helpdesk@exaco.com)



Riga XL Top Shelf

Shelf kit only available for Riga XL 5,6, & 9

Assembly Instructions - Top Shelf



Parts list top shelf:

Description	pos.	overview	Riga XL 5	Riga XL 6	Riga XL 9
<i>longitudinal profile may be trimmed to fit if desired</i>	1		4	4	6
<i>strut - 33.5 inches</i>	3		6	7	10
<i>angle-end tail (narrow)</i>	V36		12	14	22
<i>cross-brace</i>	5		6	7	10
<i>connector with grub screw</i>	V161		6	6	10
<i>hexagonal bolt M6 x 12mm with nut M6</i>	S12/S1		11	11	22
<i>hexagonal bolt M6 x 16mm with nut M6</i>	S5/S1		14	10	22
<i>T-head bolt M6 x 16mm with nut M6</i>	S15/ S1		2	2	2
<i>Allen key</i>	V21		1	1	1
<i>Polycarbonate sheets (shelf surface) In a separate box</i>			5	6	9





Riga XL Table Shelf

Shelf kit only available for Riga XL 5,6, & 9

Assembly Instructions Table Shelf

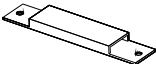

Parts list table shelf:

Description	pos.	overview	Riga XL 5	Riga XL 6	Riga XL 9
longitudinal profile <i>may be trimmed to fit if desired</i>	1		4	4	6
strut - 35.5 inches	3		6	7	10
angle-end tail (narrow)	V36		12	14	22
cross-brace	5		6	7	10
connector with grub screw	V161		6	6	10
hexagonal bolt M6 x 12mm with nut M6	S12/S1		11	11	22
hexagonal bolt M6 x 16mm with nut M6	S5/S1		14	10	22
T-head bolt M6 x 16mm with nut M6	S15/ S1		2	2	2
Allen key	V21		1	1	1
Polycarbonate sheets (shelf surface) <i>In a separate box</i>			5	6	9

Before beginning step 1 of assembly, take time to prepare your longitudinal profile:

Connect your longitudinal profiles using connectors with grub screws (may be preinserted into your longitudinal profile).



The sections of longitudinal profiles (pos 1) are connected with connectors with grub screws (V161) as shown to the left. Tighten the set screws/grub screws with included Allen wrench.

Assembly Overview:

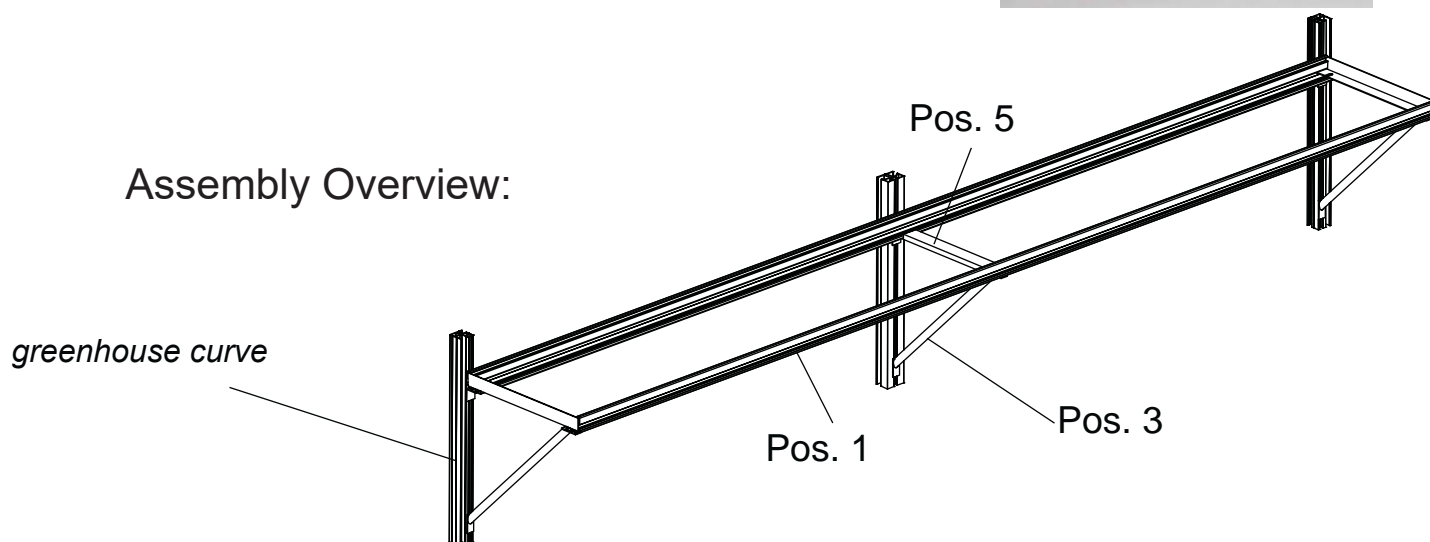

Step 1



Attach an angle-end tail (V36) to each end of the struts (pos. 3). Push in as far as it will possibly go - it is okay if it does not fully insert.

Step 2

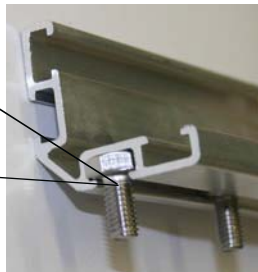
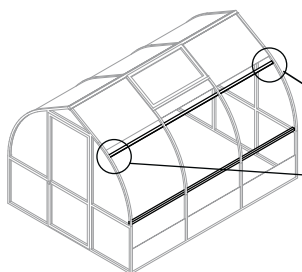

Insert one M6 x 12 bolt (S12) per greenhouse curve (including edge curves) into the lower bottom channel of the attached greenhouse lateral support.

Step 3



Insert one M6 x 12 bolt (S12) per curve of greenhouse (including the edge curves) into the lower channel on the bottom of the longitudinal profile (pos.1) of the shelf kit. Tip: Use a strip of tape to keep the bolts from sliding out the end.

Step 4



Attach the cross-braces (pos. 5) to the greenhouse lateral support with inserted bolt and nut and let them hang.

Step 5



Attach crossbrace to front longitudinal profile (from shelf kit) with inserted bolt. Add the strut assembly beneath and tighten with nut. Repeat on all curves.

Step 6



Attach strut to greenhouse curve with bolt (S5) and nut (S1). Tip: Insert bolt (S5) at the insertion point near the bottom of the curve. Please note that the black angle may not match the angle of your greenhouse curve.

Step 7



Finally, insert the polycarbonate panels

OPTIONAL ACCESSORY: Exhaust Fan installation for RIGA XL, RIGA 4 & RIGA 5

If you have both an intake shutter vent and exhaust fan, you will want them to be opposite/diagonal from each other to get the best cross-breeze. Plug the fan into the thermostat (optional) to control when it turns on. If you are using both a shutter vent and an exhaust fan you will need to purchase a plug splitter and plug them both into the thermostat.

For a Riga 4 & 5, we recommend placing the exhaust fan next to rear wall window by placing the unit on top of the cross bar to support the weight, as seen below.

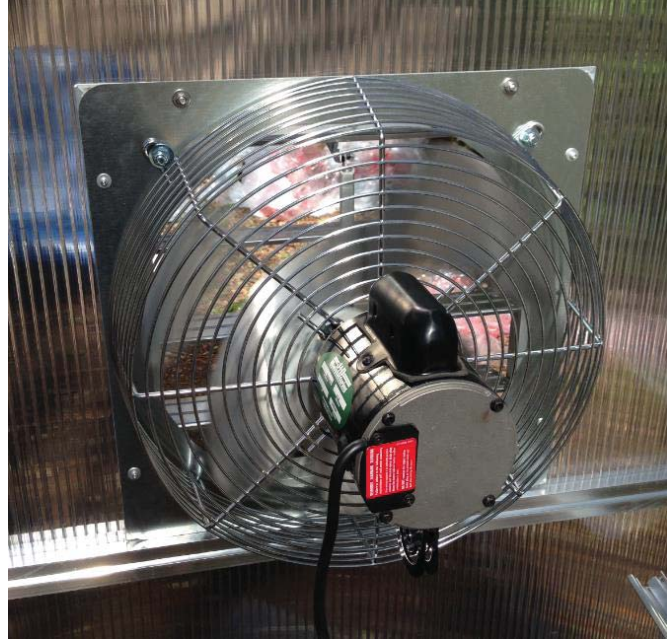

For the Riga XL the best placement is above the rear wall door with the weight on the door frame as seen to the left.

You may cut the hole in the polycarbonate before or after assembly of the greenhouse. Draw the outline of hole to be cut (only the area protruding from the polycarbonate). Drill a hole in each corner of the panel to insert a fine-tooth jigsaw blade and cut along the lines. Insert the fan. Drill holes in polycarbonate through the holes in the flange of the fan and hold in place with bolts – use washers on the outside. Once installed, we recommend caulking on the outside with neutral cure silicone caulk such as Boss 399.

OPTIONAL ACCESSORY: Intake Shutter Vent Installation for RIGA XL, RIGA 4 & 5

You will want your intake shutter vent to be opposite from your exhaust fan (i.e. opposite wall and lower part of the greenhouse) to get the best cross-breeze. They should both be plugged into the thermostat with a plug splitter to engage them simultaneously.

We recommend cutting a hole in the polycarbonate to bolt the intake shutter vent to the horizontal bar next to the front door. Measure the protruding dimensions and cut the appropriate size hole in the polycarbonate. You may cut this hole before installing the polycarbonate (see note to the right). If your greenhouse is assembled, the best way is to drill a hole in each of the corners of the section to be removed, then insert a jigsaw (fine tooth blade) to cut along your marked lines (note: if you use this method, your measurement will be different than the ones to the right).

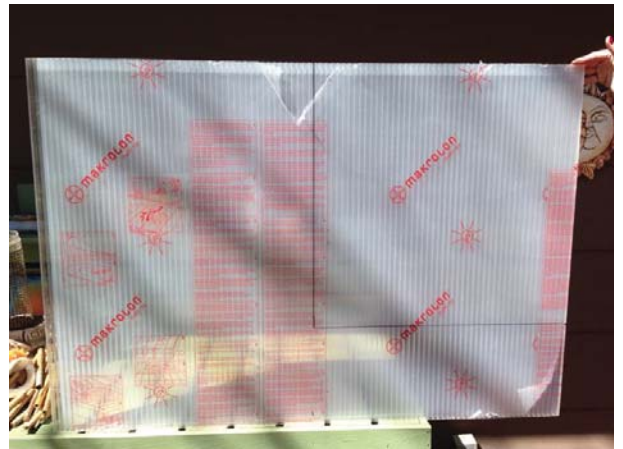

To cut the hole before installing the polycarbonate, you may use the following measurements as shown above:

- Riga 4: 16.75" w x 16.5" h
- Riga 5: 20.75" w x 20.5" h



Step 2: Bolt the “heavy/thick” L-bracket which comes with the vent to the galvanized steel “T-bracket” supplied by us, screw (self-tapping screws) the T-bracket to the bottom of the vent and cross bar (slightly off center). You may want to drill small pilot holes. Attach the “motor” to the “L-bracket” with the 4 black screws. Then follow the instructions provided with the vent. Attach the spring (only 1 is needed) to pull the vent closed at the top in a small hole drilled in the top flange. We have found that it is best to hook the chain over the top of the center bar to pull the vent open. We recommend sealing with a neutral cure silicone caulk (such as Boss 399) on the outside of the greenhouse.

Riga Metal Hook Assembly



Riga Plastic Hook Assembly

1.

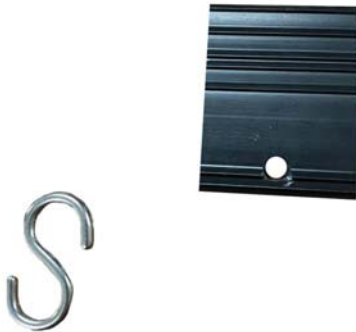

2.



3.

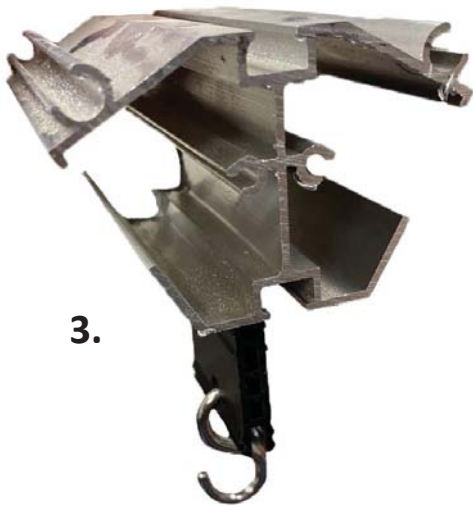

Pinch the top of the plastic hook and slide it into the ridge beam or the curve beams. Plastic hooks are designed for supporting plants/ growing wire - or other lightweight items.

Notes:



Customer Service or
Assembly Questions?

Give us a call
Toll free: 1-877-760-8500
customerservice@exaco.com
Exaco Trading
www.EXACO.com

*Please watch our animated assembly
video on our Exaco Trading Co
YouTube Channel.
Find the link at www.exaco.com*

